



SHS of Porous Materials from Nanocomposite Reactants

O.K. Mulamba

Adviser: Dr. Emily Hunt
West Texas A&M University



Objectives

The impact of this study is to provide an understanding of the preparation, combustion, reaction and possible uses of Nanostructured metallic Foams containing antibacterial properties.

- (1) evaluate how the balance of reactants influences the combustion and biological behaviors of the product foam;
- (2) Characterize the bacterial and biological properties of reactants and products;
- (3) Test and establish possible applications using biological properties results;

Sample Preparation

- The mixture is composed of 4 μm Aluminum, 800 nm Silver Oxide, and a nano-scale gassing agent: $\text{Al}/\text{C}_{13}\text{F}_{27}\text{COOH}$.
- Individual particles were immersed in a solution and mixed using ultrasonification. The solution was then evaporated on a hot plate at 40°C.
- Powder mixture was then cold pressed in a uni-axial die to create cylindrical pellets with a diameter of 6.5 mm.
- The densities of the pellets were approximately 70 % TMD.

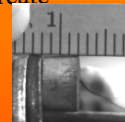

Experimental Set-up

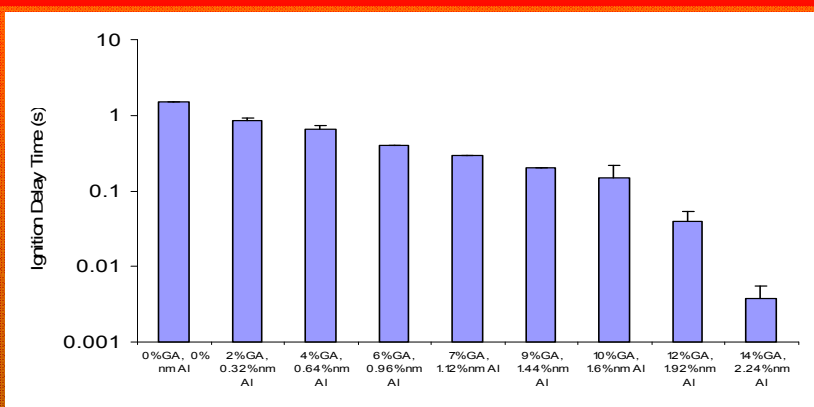
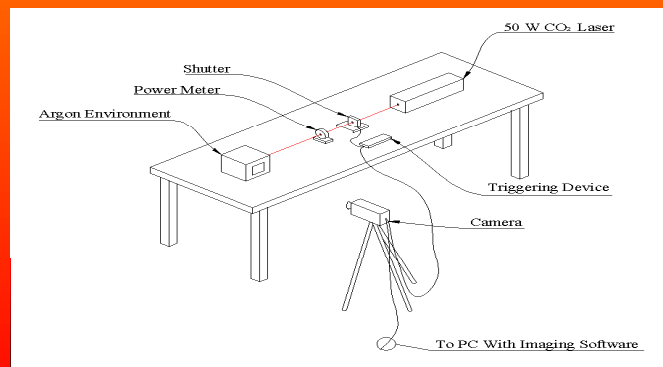

- Ignition time as a function of weight percent gassing agent was determined using thermocouple measurements and data from the high-speed camera.
- As the weight percent of gassing agent increases, the ignition time decreases.
- If the sublimation of the gassing agent can be accelerated by reducing the diameter of the particles, the overall reaction would be accelerated as well.

Ignition Temperature

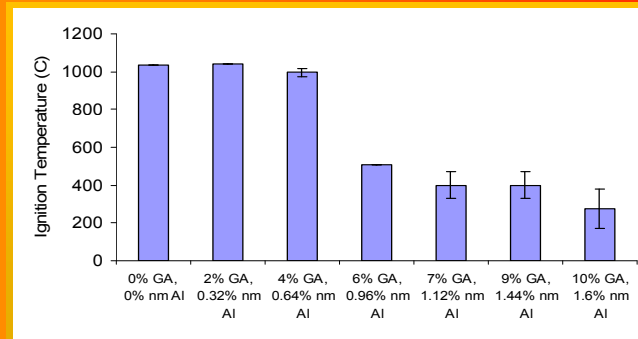

- Ignition temperature as a function of weight percent of gassing agent was determined using type C thermocouples.
- Approximately 4 pellets were used in each test group (weight percent gassing agent).
- Ignition temperature is lower than the original Ag_2OAl alloy (0 wt % gassing agent) when the total weight percent of $\text{Al}/\text{C}_{13}\text{F}_{27}\text{COOH}$ reaches 6.

Elongation

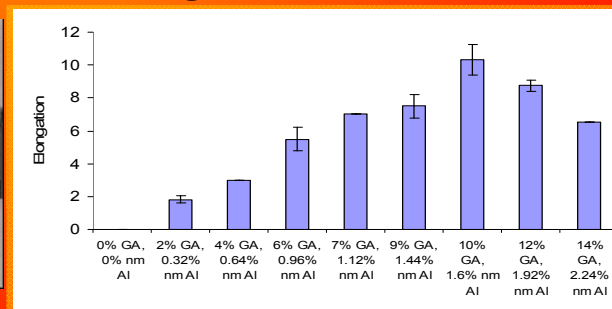

- Elongation as a function of weight percent of gassing agent was determined using the high-speed camera and software.
- The elongation continues to increase until it reaches 10 wt % gassing agent.
- Once the wt % gassing agent reaches 16, the reaction becomes too exothermic and the pellet cannot maintain the original shape.

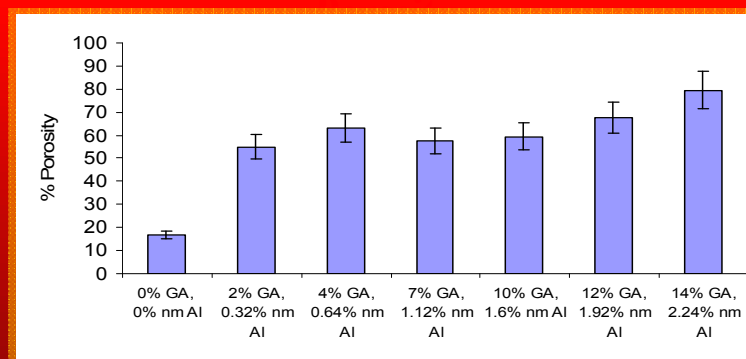

- An important feature of cermet materials is the high percentage of porosity associated with the products which corresponds to the heat insulation property.
- Porosity testing was conducted by Porous Materials, Inc. in Ithaca, NY. The method used for porosity measurements is analogous to hydrostatic weighing.
- The results show that porosity continues to increase with increasing weight percentages of gassing agent.

Product Microstructure

Ag_2OAl wt% $\text{Al}/\text{C}_{13}\text{F}_{27}\text{COOH}$

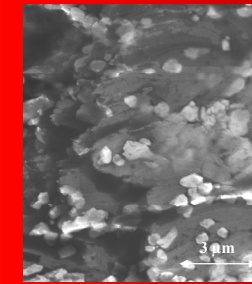

unburned

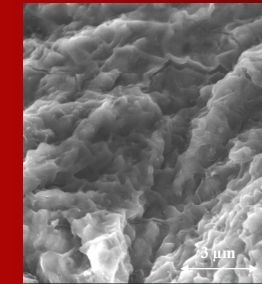

burned

Ag_2OAl 10 wt% $\text{Al}/\text{C}_{13}\text{F}_{27}\text{COOH}$

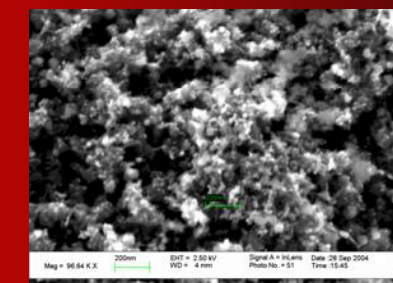
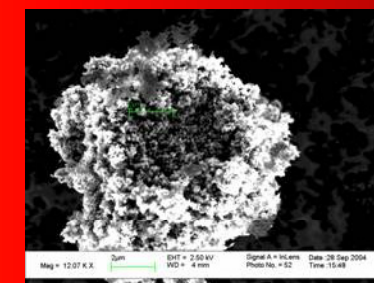

Ag_2OAl 12 wt% $\text{Al}/\text{C}_{13}\text{F}_{27}\text{COOH}$

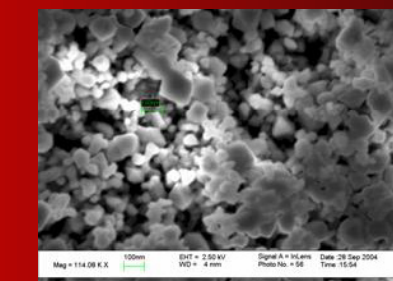
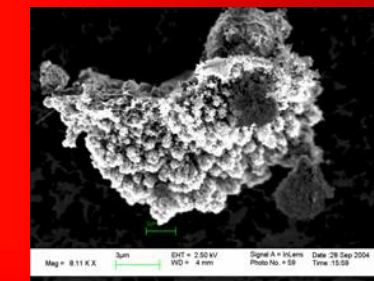

Conclusions

- Ignition temperature and time of the alloy decreases as the weight percent of gassing agent increases, which leads to improved combustion performance in the cermet material.
- Based on the SEM micrographs and hydrostatic weighing, the products of the materials with gassing agent added are more porous than those without which leads to increased heat-insulation properties in the material.
- The elongation of the sample depends on the gas pressure in the pores of the sample which can be controlled by varying the amount of gassing agent in the green mixture. The sample will continue to elongate until a critical amount of gassing agent is added.
- Thus, a new material is formed with under normal gravity conditions that exhibits increased porosity and elongation effects comparable to experiments performed under micro-gravity conditions.